

Low On-Resistance Wideband/Video Quad 2-Channel Mux/DeMux

Features

- High-performance solution to switch between video sources
- Wide bandwidth: 400 MHz (typical)
- Low On-Resistance: 5Ω (typical)
- Low crosstalk at 10 MHz: -56dB
- Ultra-low quiescent power (0.1μA typical)
- Single supply operation: +5.0V
- Packaging (Pb-free & Green Available):
 - 16-pin 300-mil wide plastic SOIC (S)
 - 16-pin 150-mil wide plastic SOIC (W)
 - 16-pin 150-mil wide plastic QSOP (Q)

Description

Pericom Semiconductor's PI5V330 is a true bidirectional Quad 2-channel multiplexer/demultiplexer recommended for both RGB and composite video switching applications. The video switch can be driven from a current output RAMDAC or voltage output composite video source.

Low On-Resistance and wide bandwidth make it ideal for video and other applications. Also this device has exceptionally high current capability which is far greater than most analog switches offered today. A single 5V supply is all that is required for operation.

The PI5V330 offers a high-performance, low-cost solution to switch between video sources. The application section describes the PI5V330 replacing the HC4053 multiplier and buffer/amplifier.

Block Diagram

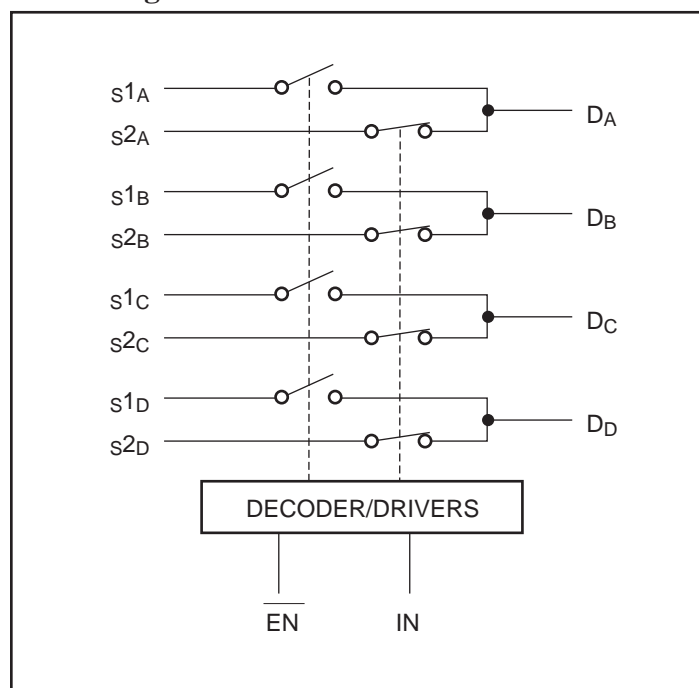

Truth Table

EN	IN	ON Switch
0	0	s1A, s1B, s1C, s1D
0	1	s2A, s2B, s2C, s2D
1	X	Disabled

Pin Configuration

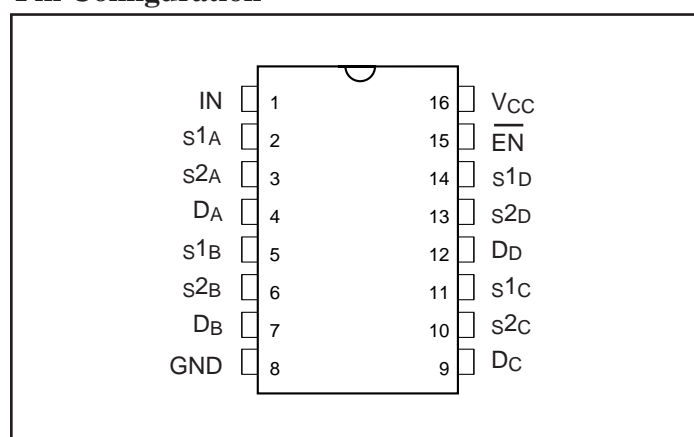

Pin Description

Pin Name	Description
s1A, s1B, s1C, s1D s2A, s2B, s2C, s2D	Analog Video I/O
IN	Select Input
EN	Enable
DA, DB DC, DD	Analog Video I/O
GND	Ground
VCC	Power

Maximum Ratings

(Above which the useful life may be impaired. For user guidelines, not tested.)

Storage Temperature	-65°C to +150°C
Ambient Temperature with Power Applied	-40°C to +85°C
Supply Voltage to Ground Potential (Inputs & V _{CC} Only)...	-0.5V to +7.0V
Supply Voltage to Ground Potential (Outputs & D/O Only)	-0.5V to +7.0V
DC Input Voltage	-0.5V to +7.0V
DC Output Current.....	120mA
Power Dissipation	0.5W

Note:

Stresses greater than those listed under MAXIMUM RATINGS may cause permanent damage to the device. This is a stress rating only and functional operation of the device at these or any other conditions above those indicated in the operational sections of this specification is not implied. Exposure to absolute maximum rating conditions for extended periods may affect reliability.

DC Electrical Characteristics (Over the Operating Range, T_A = -40°C to +85°C, V_{CC} = 5V ±5%)

Parameters	Description	Test Conditions ⁽¹⁾	Min.	Typ. ⁽²⁾	Max.	Units
V _{ANALOG}	Analog Signal Range		0		2.0	V
V _{IH}	Input HIGH Voltage	Guaranteed Logic HIGH Level	2.0			
V _{IL}	Input LOW Voltage	Guaranteed Logic LOW Level	-0.5		0.8	
I _{IH}	Input HIGH Current	V _{CC} = Max., V _{IN} = V _{CC}			±1	μA
I _{IL}	Input LOW Current	V _{CC} = Max., V _{IN} = GND			±1	
I _O	Analog Output Leakage Current	0 ≤ S1, S2 or D ≤ V _{CC} , Switch OFF			±1	
V _{IK}	Clamp Diode Voltage	V _{CC} = Min., I _{IN} = -18mA	-0.7	-1.2		V
V _H	Input Hysteresis at Control Pins			150		mV
R _{ON}	Switch On-Resistance ⁽³⁾	V _{CC} = Min., V _{IN} = 1.0V, I _{ON} = 13mA		5	7	Ω
		V _{CC} = Min., V _{IN} = 2.0V, I _{ON} = 26mA		7	10	

Notes:

- For Max. or Min. conditions, use appropriate value specified under Electrical Characteristics for the applicable device type.
- Typical values are at V_{CC} = 5.0V, T_A = 25°C ambient and maximum loading.
- Measured by the voltage drop between S1, S2, and D I/O pins at indicated current through the switch. On-Resistance is determined by the lower of the voltages on the S1, S2, and D I/O pins.

Dynamic Characteristics (Over the Operating Range, $T_A = -40^\circ\text{C}$ to $+85^\circ\text{C}$, $V_{CC} = 5V \pm 5\%$)

Parameters	Description	Test Conditions	Min.	Typ.	Max.	Unit
t_{ON}	Turn On Time	$R_L = 75\Omega$, $C_L = 20\text{pF}$, See Fig. 4		2.5	5	ns
t_{OFF}	Turn Off Time	$R_L = 75\Omega$, $C_L = 20\text{pF}$, See Fig. 4		1.1	5	
$BW^{(1)}$	-3 dB Bandwidth	See Fig. 5			400	MHz
X_{TALK}	Crosstalk	10MHz, See Fig. 5		-80		dB
$C_{IN}^{(1)}$	Input/Enable Capacitance	$V_{IN} = 0V$, $f = 1\text{ MHz}$			6	pF
$C_{OFF}^{(1)}$	Capacitance, Switch Off	$V_{IN} = 0V$, $f = 1\text{ MHz}$			6	
$C_{ON}^{(1)}$	Capacitance, Switch On	$V_{IN} = 0V$, $f = 1\text{ MHz}$			9	
O_{IRR}	Off Isolation	10MHz, See Fig 5		-56		dB

Notes:

- This parameter is determined by device characterization but is not production tested.

Power Supply Characteristics

Parameters	Description	Test Conditions ⁽¹⁾		Min.	Typ ⁽²⁾	Max.	Units
I_{CC}	Quiescent Power Supply Current	$V_{CC} = \text{Max.}$	$IN = \text{GND or } V_{CC}$		0.1	3.0	μA
ΔI_{CC}	Supply Current per Input @ TTL HIGH	$V_{CC} = \text{Max.}$	$IN = 3.4V^{(3)}$			2.5	mA
I_{CCD}	Supply Current per Input per MHz ⁽⁴⁾	$V_{CC} = \text{Max.}$, S1, S2 and D Pins Open $\overline{EN} = \text{GND}$ Control Input Toggling 50%Duty Cycle				0.25	mA/ MHz

Notes:

- For Max. or Min. conditions, use appropriate value specified under Electrical Characteristics for the applicable device.
- Typical values are at $V_{CC} = 5.0V$, $+25^\circ\text{C}$ ambient.
- Per TTL driven input ($V_{IN} = 3.4V$, control inputs only); S1, S2, and D pins do not contribute to I_{CC} .
- This current applies to the control inputs only and represent the current required to switch internal capacitance at the specified frequency. The S1, S2, and D I/O pins generate no significant AC or DC currents as they transition. This parameter is not tested, but is guaranteed by design.

Definitions

Symbol	Description
R_{ON}	Resistance between source and drain with switch in the ON state.
I_O	Output leakage current measured at S1, S2, and D with the switch OFF.
V_{IN}	Digital voltage at the IN pin that selects between S1 and S2 analog inputs.
V_{EN}	A voltage that ENABLES the chip.
C_{IN}	Capacitance at the digital inputs.
C_{OFF}	Capacitance at analog I/O (S1, S2, D) with switch OFF.
C_{ON}	Capacitance at analog I/O (S1, S2, D) with switch ON.
V_{IH}	Minimum input voltage for logic HIGH.
V_{IL}	Minimum input voltage for logic LOW.
I_{IH} (I_{IL})	Input current of the digital input.
t_{ON}	Propagation delay measured between 50% of the digital input to 90% of the analog output when switch is turned ON. The peak analog voltage is 0.714V.
t_{OFF}	Propagation delay measured between 50% of the digital input to 90% of the analog output when switch is turned OFF. The peak analog voltage is 0.714V.
BW	Frequency response of the switch in the ON state measured at 3dB down.
X_{TALK}	Is an unwanted signal coupled from channel to channel. Measured in -dB. $X_{TALK} = 20 \text{ LOG } V_{OUT}/V_{IN}$. This is non-adjacent crosstalk.
O_{IRR}	Off isolation is the resistance (measured in -dB) between the input and output with the switch off (NO).

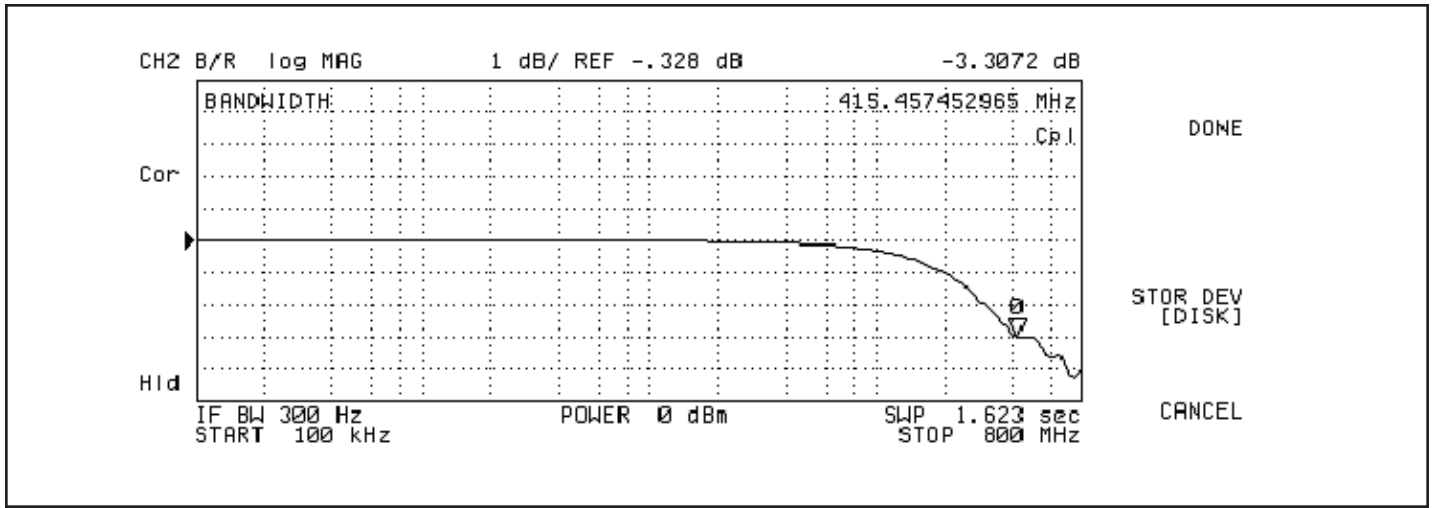

Figure 1. Gain vs Frequency

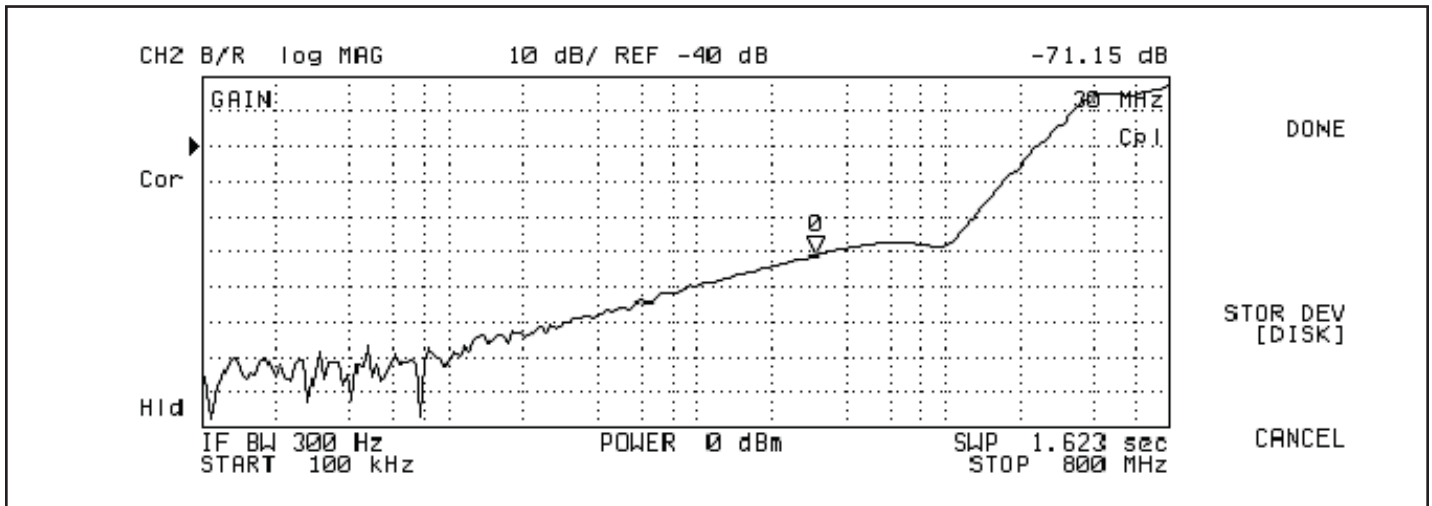

Figure 2. Off Isolation vs Frequency

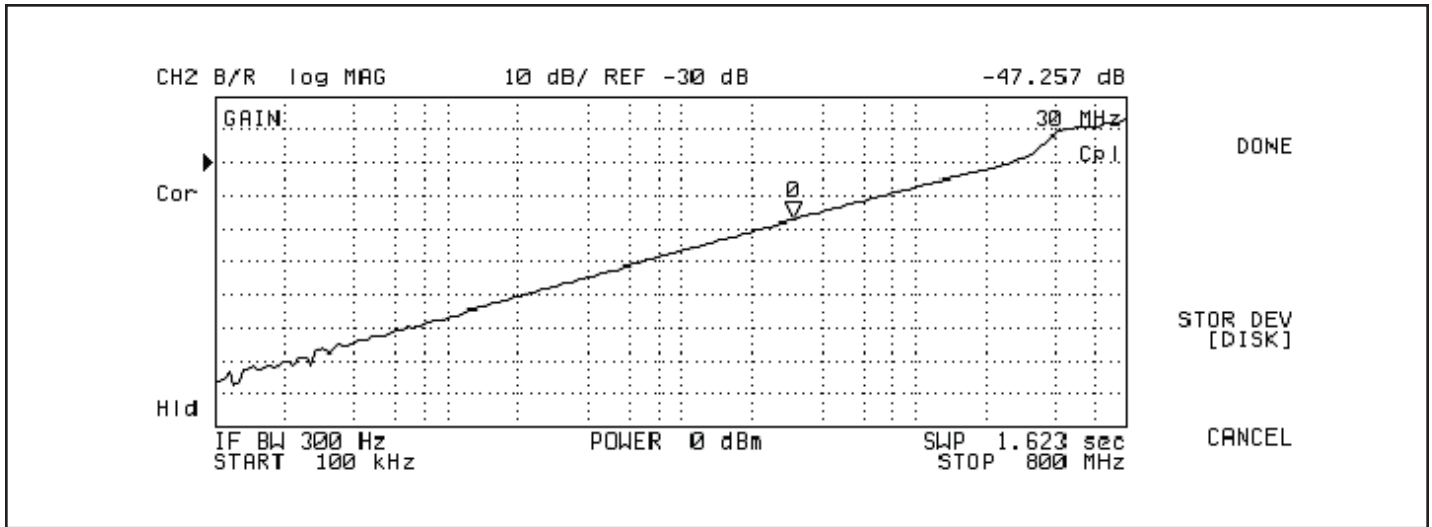

Figure 3. Crosstalk vs Frequency

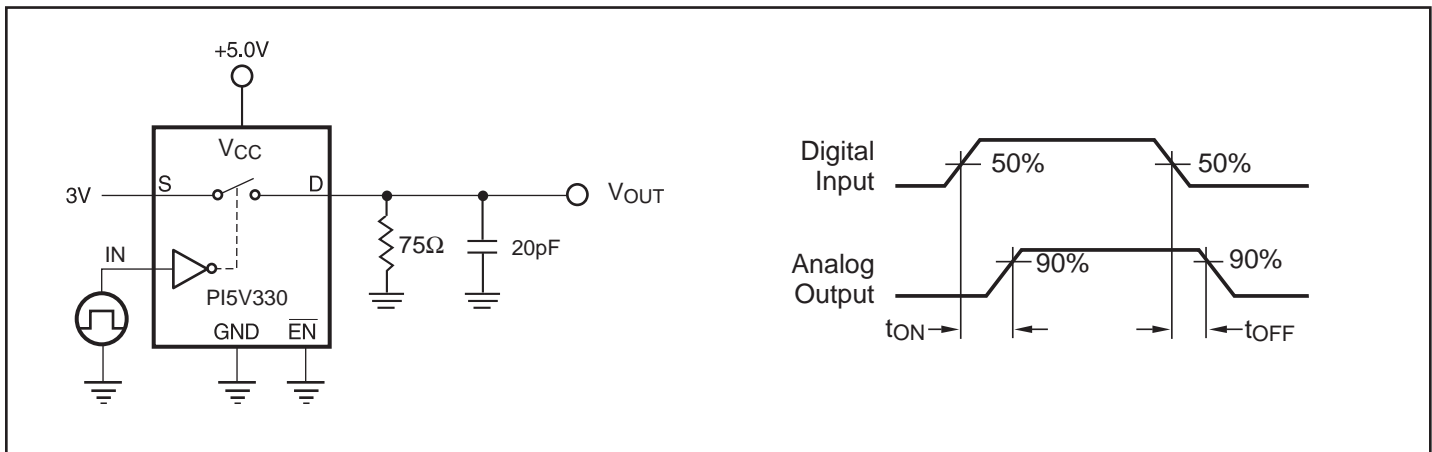

Figure 4. Switching Time

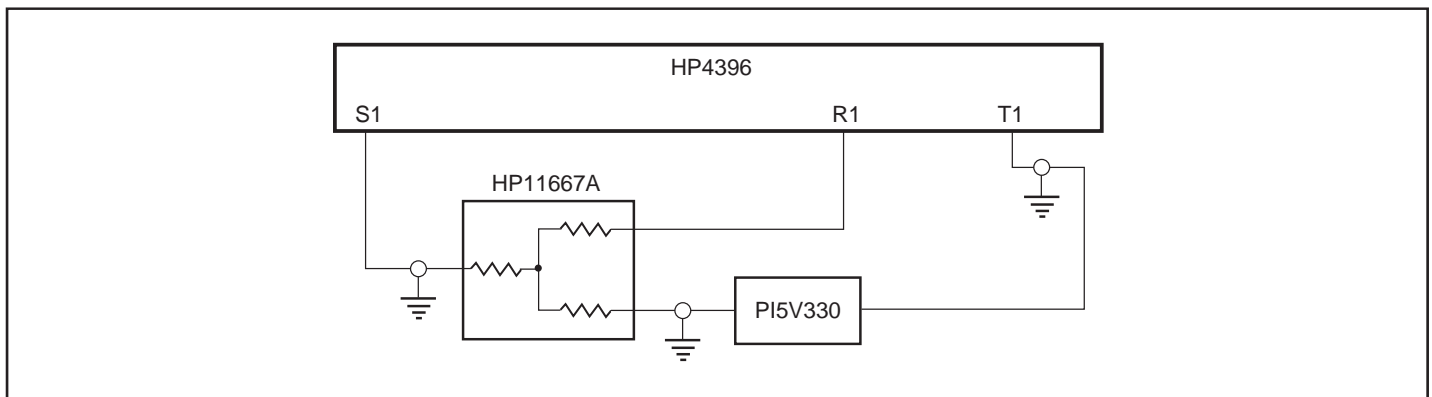
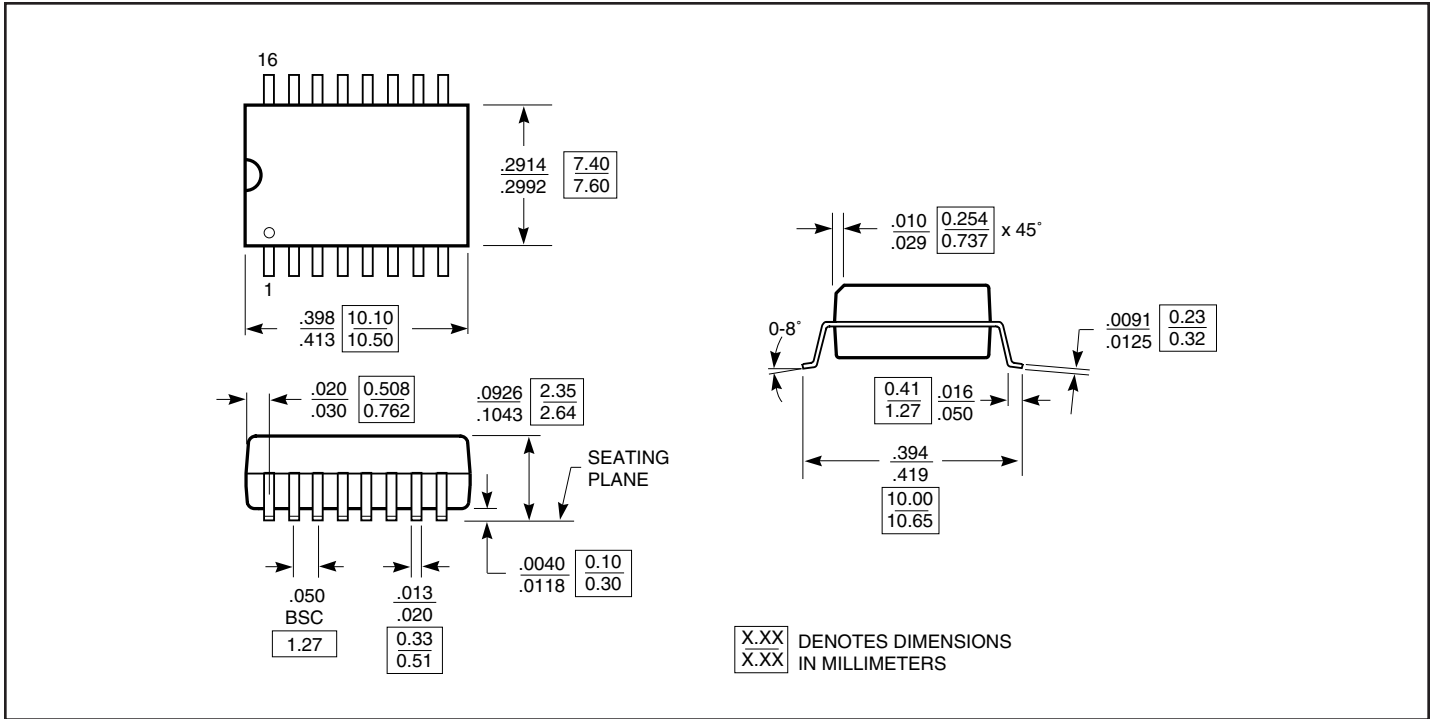
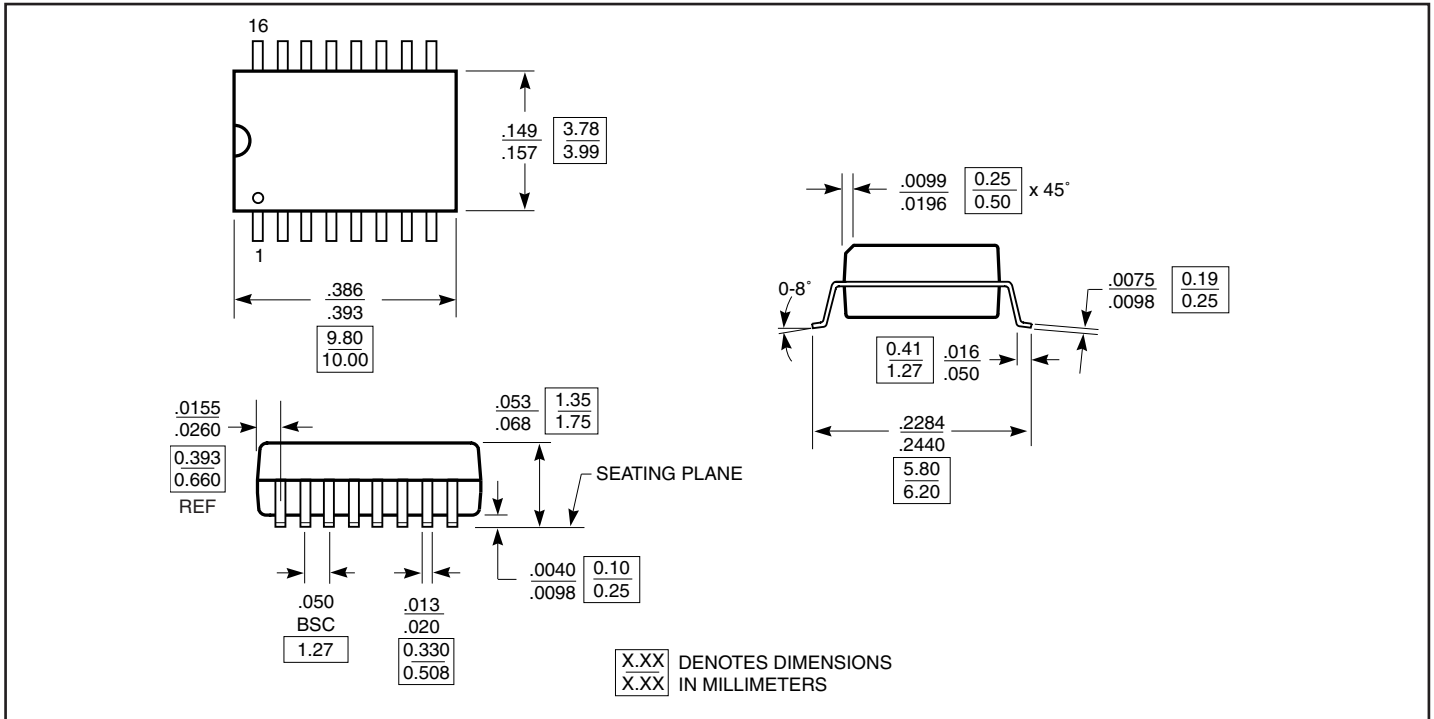

Figure 5. Gain/Phase, Crosstalk, Off-Isolation

Packaging Mechanical: 16-pin SOIC (S)



Packaging Mechanical: 16-pin SOIC (tW)



Packaging Mechanical: 16-pin QSOP (Q)

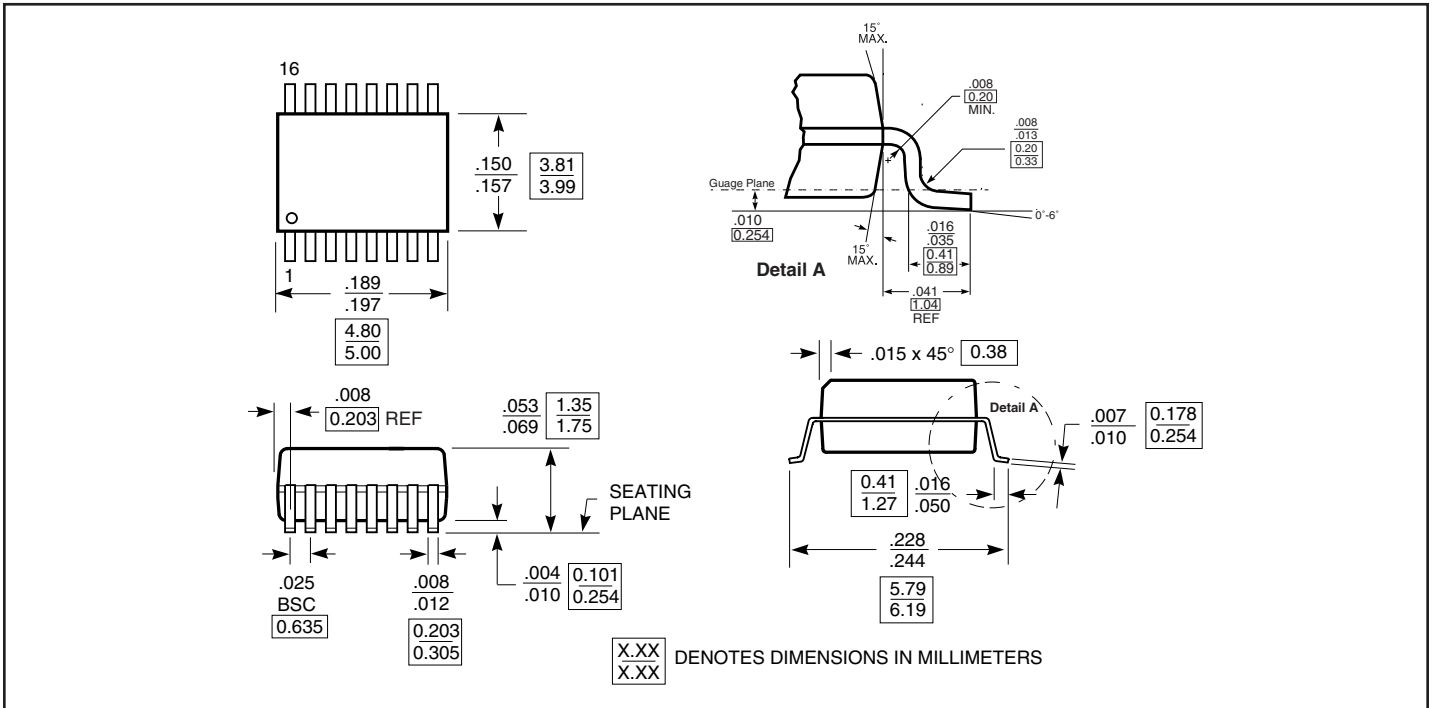

Ordering Information

Ordering Code	Package Code	Package Description
PI5V330SE	S	Pb-free & Green, 16-pin 300-mil wide plastic SOIC
PI5V330W	W	16-pin 150-mil wide plastic SOIC
PI5V330WE	W	Pb-free & Green, 16-pin 150-mil wide plastic SOIC
PI5V330Q	Q	16-pin 150-mil wide plastic QSOP
PI5V330QE	Q	Pb-free & Green, 16-pin 150-mil wide plastic QSOP

Notes:

1. Thermal characteristics can be found on the company web site at www.pericom.com/packaging/